

# DEVELOPMENT OF LOW LEVEL RF CONTROL SYSTEMS FOR SUPERCONDUCTING HEAVY ION LINEAR ACCELERATORS, ELECTRON SYNCHROTRONS AND STORAGE RINGS \*

M. Pekeler, C. Piel Accel GmbH, Bergisch Gladbach, Germany.

B. Aminov, A. Borisov, S. Kolesov, H. Piel, Cryoelectra GmbH, Wuppertal, Germany

## Abstract

Since 2001 ACCEL Instruments is supplying low level RF control systems together with turn key cavity systems. The early LLRF systems used the established technology based on discrete analogue amplitude and phase detectors and modulators. Today analogue LLRF systems can make use of advanced vector demodulators and modulators combined with a fast computer controlled analogue feed back loop. Feed forward control is implemented to operate the RF cavity in an open loop mode or to compensate for predictable perturbations. The paper will introduce the general design philosophy and show how this can be adapted to different tasks as controlling a synchrotron booster nc RF system at 500 MHz, or a sc storage ring rf, as well as a the superconducting 176 MHz accelerating cavities of a linear accelerator at 176 MHz with multiple cavities individual driven and controlled.

## INTRODUCTION

In the following chapters we describe in detail and as an example the architecture of a computer controlled fast analogue low level RF control system for the injector and pre accelerator section of a superconducting linear accelerator consisting of one normal conducting Radio Frequency Quadrupole (RFQ) and six superconducting half wave resonators (HWR) operated at 176 MHz.

Table 1: Technical Specification of the LLRF for the superconducting HWRs.

Cavity Parameters	Unit	Value
Cavity centre frequency	MHz	176
Cavity bandwidth	Hz	120
Gradient	MV/m	10
Number of sc. Cavities		6
LRF loop gain	dB	40
Phase stability	degree	± 0.5
Amplitude stability	%	± 0.5
Setability of piezo/mechanical tuner	Hz	± 1

## LOW LEVEL RF SYSTEM

The LLRF consists of a fast analogue section (FAS) and a digital control section (DCS). The DCS provides the setting and the control of phase and amplitude of the accelerating field in each individual rf-structure. It can be

programmed according to the various operation modes of the linear accelerator, so that the excitation of each rf structure (HWR or RFQ) can be controlled separately. Table 1 and Table 2 summarise the technical data for the LLRF system for HWR and RFQ.

Table 2: Technical Specification of the LLRF for the Radio Frequency Quadrupole.

RFQ Parameters	Unit	Value
RFQ centre frequency	MHz	176
RFQ bandwidth	kHz	21
Output energy	MeV	1.5
LLRF loop gain	dB	40
Phase stability	degree	± 0.5
Amplitude stability	%	± 0.5
Setability of mechanical tuner	Hz	± 75

## Low Level RF Fast Analogue Section

The block-diagram of the Low Level RF system is shown in Figure 1. An RF probe coupled to the RF field of the HWR (or RFQ) delivers an RF signal, which carries the information on amplitude and phase of the accelerating field in the structure. Both parameters are generally modulated due to variations of the resonant frequency  $f_0$  (eigenfrequency) of the resonant structure, which may be influenced by microphonics, pressure and temperature variations, beam loading or other phenomena, like multipacting, field emission or quenching. In the LLRF fast amplitude and phase deviations of the HWR field relative to amplitude and phase of the master oscillator are compared with table values, delivered by the DCS of the LLRF. The deviations from these preset values are amplified and act either in a fast feed back loop of the FAS to readjust phase and amplitude of the input signal to the HPA or to trigger an interlock signal. By this process the RF field parameters in the HWR are maintained constant on a time scale small compared to the time constant of the superconducting HWR cavity or the RFQ.

Slow changes of phase and amplitude of the HWR field relative to phase and amplitude of the RF drive signal at the input coupler of the HWR are used to control the piezoelectric and/or mechanical tuner of the structure. The operation of the piezoelectric and mechanical tuners are controlled by the DCS of the LLRF.

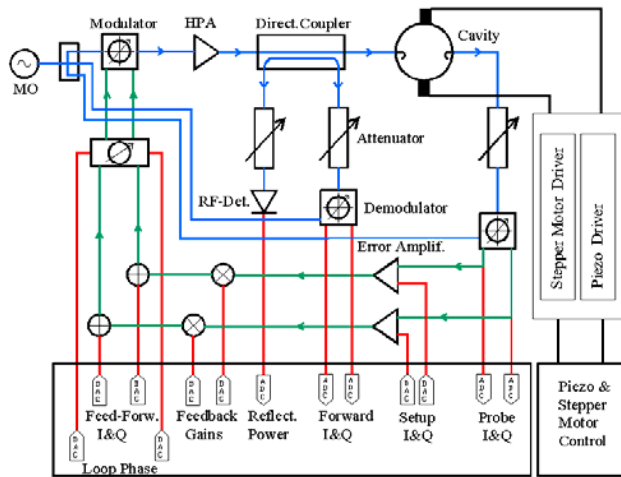

Figure 1: Low Level RF block-diagram.

The FAS has three RF inputs: the LO input from the RF Generator, the RF monitor signal of the forward RF power to the HWR and the transmitted signal from the HWR probe. The measured RF signals of the forward and the transmitted power are attenuated by voltage controlled attenuators and demodulated by I&Q demodulators. The I&Q values carry the full information on the amplitude and phase of the RF signals. The I&Q values are compared with the corresponding set values delivered by the DCS. The error signals are amplified and added to the reference I&Q values by instrumentation amplifiers. The control gain is regulated by I&Q multipliers. The sum of the reference I&Q values and the error signals are delivered to the I&Q modulator closing the fast control loop.

Figure 2 presents the printed circuit board (PCB) of the FAS, which has Euro card dimensions. All functional blocks are enclosed by shielding covers, in order to avoid parasitic coupling between RF and DC lines.

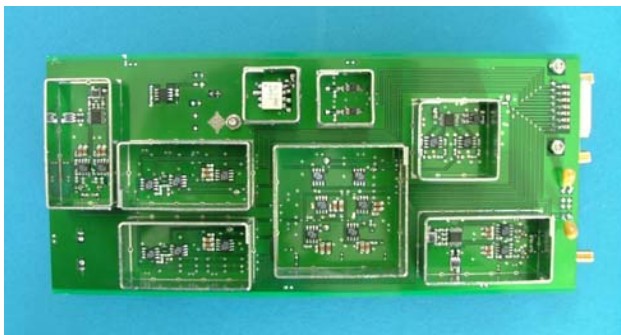

Figure 2: Low Level RF print board. The covers of the electromagnetic shields of individual sections are removed

### Low Level RF Digital Control Section

The control software is based on LabView [2] of National Instruments. It consists of separated layers: a graphical user interface which visualises the accelerator system and its functions to the operator, and a hardware

driver layer which manages the communication with each device and translates digital values to physical quantities and vice versa.

The control software allows the access to all relevant parameters of the accelerator system. The settings of adjustable parameters can be changed for optimisation, can be saved in data files for future use and can be restored from saved files.

The DCS is based on a commercial PXI system of National Instruments.

The DCS tasks are:

- monitoring I&Q values of forward and transmitted RF signals,
- monitoring the reflected RF Power signal,
- providing the set and reference values of the I&Q components,
- adjusting the control gains in the feedback loop,
- cavity quench control,
- stepper motor and piezo limits control,
- driving the stepper motor and piezo-actuator controllers to adjust the resonance frequency of the HWR
- providing communication between PXI and control computer

There are two stepper motors and two piezo elements on both sides of the cavity, changing the resonant frequency. The stepper motors are used for coarse cavity tuning. The piezo actuators are used for fine cavity tuning. The tuning loop is to control the resonant frequency of the cavity. The cavity may be operated on tune, i.e. at the frequency of the incident RF, or deliberately offset in frequency for matching to the RF generator and for beam stability. A digital PID control loop is then enabled to hold the cavity on tune.

### Local Area Network

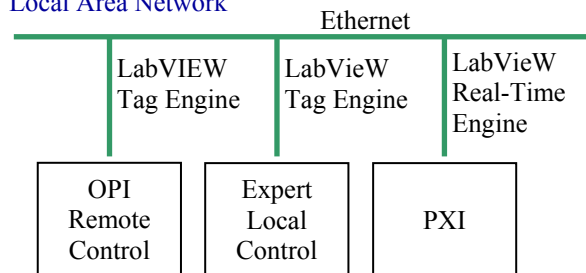

Figure 3: Low Level RF communication network and software interface.

The organization of the communication network between operator and local LLRF level is shown in Figure 3. The data transfer is realized using fast Ethernet link. There are three software levels controlling the LLRF. The highest level is the operator level (OPI). OPI starts and stops the LLRF operation, determines the cavity gradient, phase and detuning angle, and manages alarms information.

The local expert level is responsible for the input of local parameters, such as cavity or high power amplifier parameters, LLRF operation, alarm and sequential

control. The expert has the possibility to run the LLRF in manual mode for LLRF tests or cavity conditioning. The PXI level is used for the data handling and motion control during operation.

### Low Level RF System Rack Assembly

The low level RF 19"-rack assembly is shown in Figure 4. The assembly consists of:

- Control PC with keyboard and monitor (1),
- Seven analogue LLRF units (2),
- Signal distribution interface for the analogue signals controlling the LLRF (3),
- PXI 19"-chassis with controller, analogue Input & Output and motion control boards with shielded cables (4),
- Signal distribution interface for the tuning loop control signals (5),
- Stepper motor drivers (6)

The piezo-actuator control drivers are placed in the separate rack.

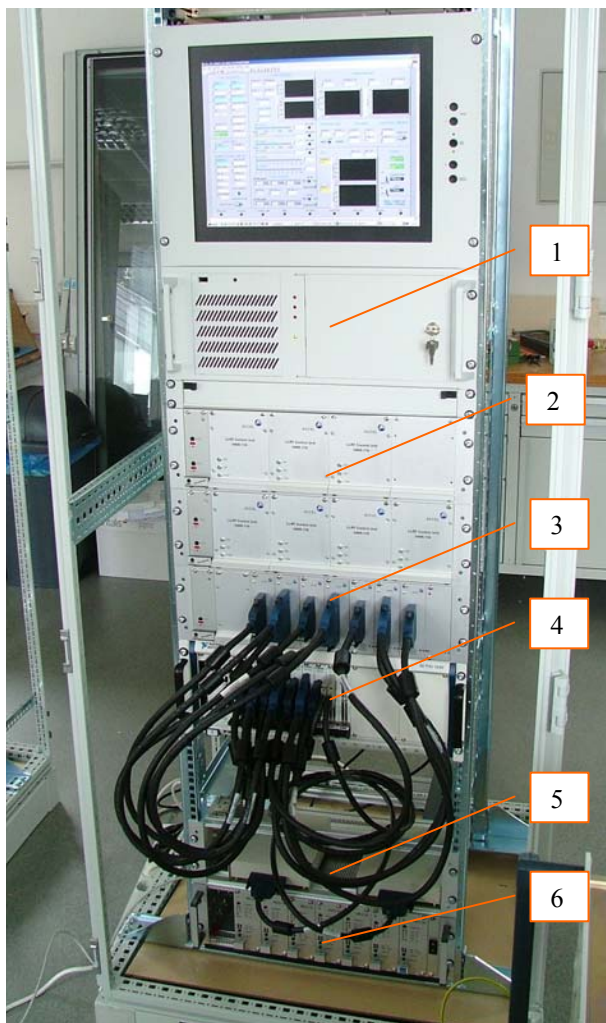

Figure 4: Low Level RF Control Rack. See text above for the legend.

### LLRF Test Facility

In order to have the possibility to test the LLRF hardware a digitally controlled cavity simulator has been designed and built (see Figure 5). The cavity simulator permits to simulate the effect of microphonics vibrations and beam current loading on the amplitude and phase of the RF signal, taking into account the cavity bandwidth. Simultaneously all RF channels can be tested and calibrated.

In addition, the cavity simulator permits to test and optimise the LLRF control programs. This feature may avoid potentially time consuming and critical tests with the real cavity. The LLRF system can be tested at different operating conditions: open and closed loop, various amplitude and phase values, feed-back gain and feed-forward values.

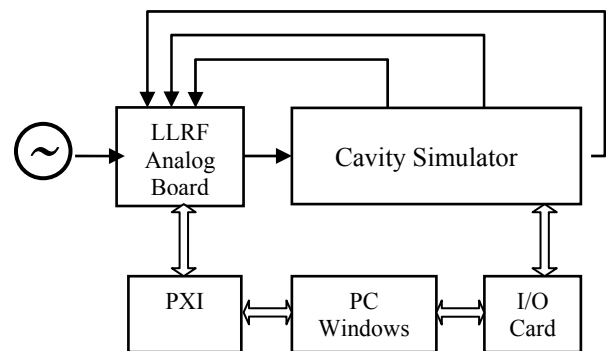

Figure 5: Block diagram of Low Level RF test assembly.

### LLRF for Electron Synchrotrons

We are presently fabricating a LLRF systems for a Booster Electron Synchrotrons with normal-conducting cavity, and for an Electron Synchrotrons Storage Ring with superconducting accelerating cavities. The main difference of these LLRF-systems compared to the one described in this article are the operating frequency of 500 MHz, the requirements for the operation stability within a high dynamic range of the field amplitude in the accelerating structure (up to 26dB for the Booster Cavity) and the interaction of the synchrotron oscillation in the beam loading with the LLRF control. This work is going on successfully and will be described in detail in a future publication.

### ACNOWLEDGMENTS

We want to express our thanks to S.Simrock for many helpful discussions and excellent suggestions.

### REFERENCES

- [1] B. Aminov, A.Borisov, S. Kolesov, , C. Piel, H. Piel, "Development of a Solid State RF Amplifier in the kW Regime for Application with Low Beta Superconducting RF Cavities", this Proceedings
- [2] LabVIEW, National Instruments, www.ni.com